

Technical Data Sheet

Rytons Acoustic AirLiner® '9x3'

(Sound, Light and Draught Reducing)

www.vents.co.uk (search code: TAL4000)

May 2010

Dimensional Drawing

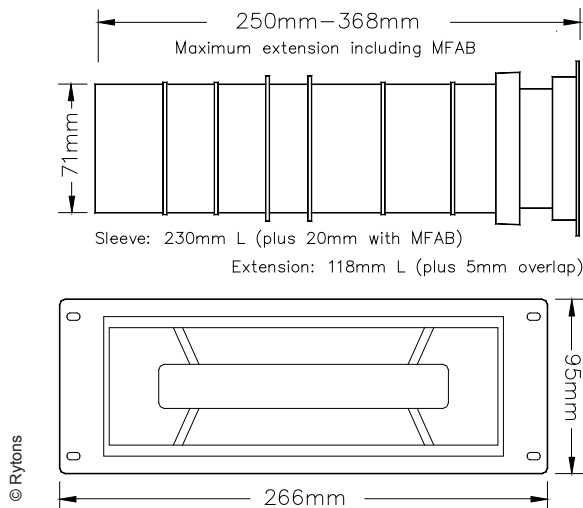

In-Situ Line Drawing

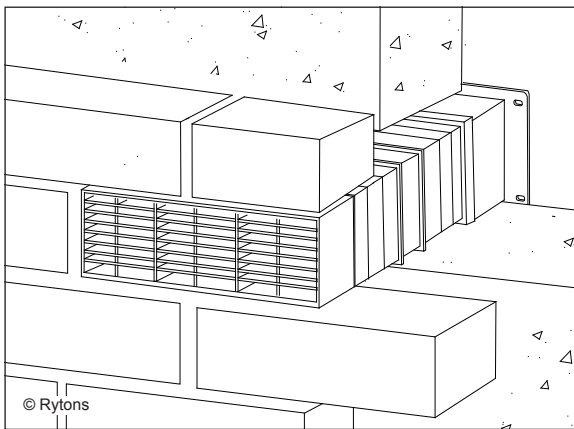
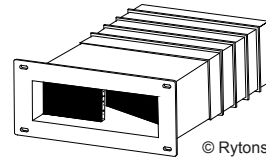
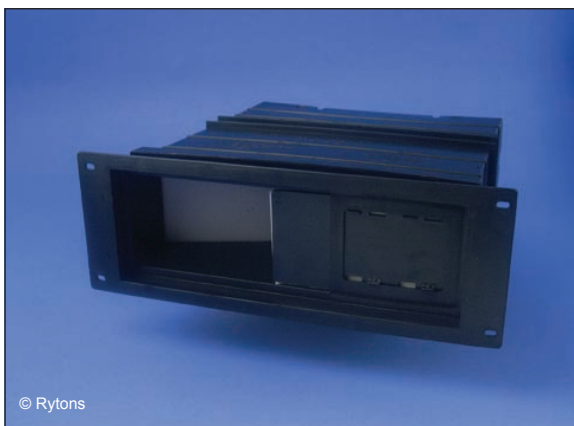

Photo Library



Approvals and Testing



Main Uses, Features and Benefits

- Acoustic telescopic cavity liner.
 - Internal baffle reduces sound, light and draughts.
 - Available as part of a set for background and appliance ventilation.
- Refer to Rytons Acoustic Ventilators Product Guide for details.

Product Specification Code	Free Area
Rytons TAL4000	4000mm ² (40cm ²) (6"²) per unit

Size

220mm (W) x 71mm (H).

Extends from 250mm to 368mm (L) with Rytons Multifix® Air Brick fitted.
AutoCAD drawing available by email.

Composition

Rigid Liner: Polypropylene. *Contains recycled plastic.*

Insert Sleeve: Polypropylene containing sound absorbent foam panels.

Colours

Black.

Specification Paragraph

Manufacturer: Rytons Building Products Ltd

T: 01536 511874, F: 01536 310455, E: admin@rytons.com

Visit our website at www.vents.co.uk

Product ref: Rytons Acoustic AirLiner® '9x3' (ref TAL4000 to BBA 94/3071)

Installation

No special fixing required. Build in cavity liner with a fitted air brick as work proceeds. Extend telescopic sleeve as necessary. Finish off internal area with a Rytons Louvre or Hit & Miss Ventilator.

Extra Features and Benefits

External water baffles prevent transfer of water across the cavity.

BBA Approval

Rytons has 73 British Board of Agrément approved products; the largest range on the market. BBA certification is third party evaluation and accreditation, and approved products are accepted by building control officers, architects, engineers and surveyors nationwide. The NHBC also accept products approved by the BBA when used as stated in the relevant BBA certificate. Rytons also has an Irish Building Regulation Statement for each of their three BBA certificates.

Handling Information

Box quantity: 20 number.

Box size: 81cm (W) x 47.5cm (H) x 27.5cm (D).

Box weight: 7kg.



Please recycle printouts where facilities exist.