

## Technical Data Sheet

### Rytons Horizontal Adaptor

#### Dimensional Drawing

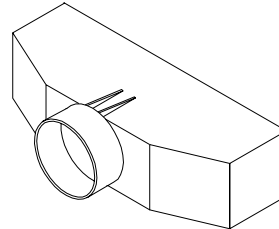
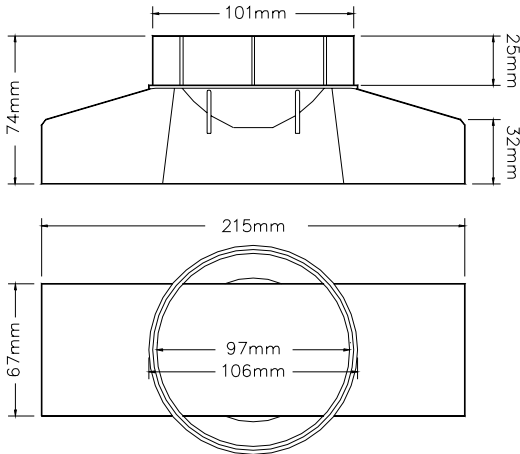

#### Main Uses, Features and Benefits

- Allows a connection from Rytons Non-Telescopic AirLiner® (TCL8LNR) to 100mm (4") diameter flexible ducting.
- Allows a connection from Rytons Periscope® Underfloor Ventilator (PUFV) to rigid ducting e.g. soil pipe for ventilation to isolated floor areas.

#### In-Situ Line Drawings

Rytons HADAP100 in conjunction with Rytons '9 x 3' Non-Telescopic AirLiner® (TCL8LNR)

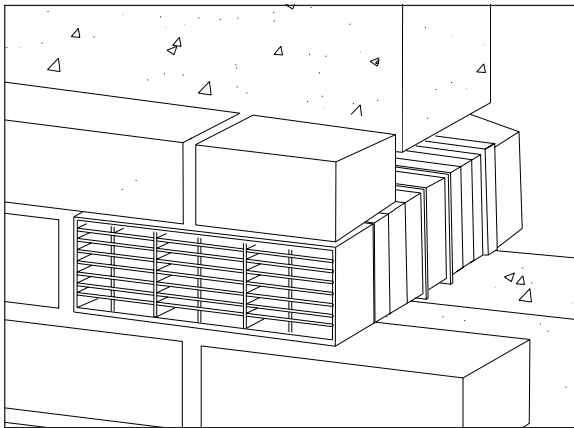

Rytons HADAP100 in conjunction with Rytons Periscope® Underfloor Ventilator (PUFV)

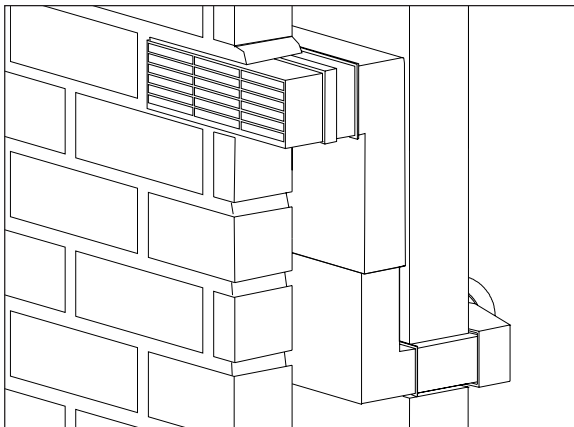

#### F30 Accessories/Sundry Items for Brick/Block/Stone Walling

Specification Clauses 17, 171

#### U80 Air Ductwork and Ancillaries

Specification Clause 340

#### U90 General Ventilation -Domestic

Specification Clause 420



#### Product Specification Code

Rytons HADAP100.

#### Size

215mm (L) x 67mm (H) x 49mm (D) (excluding tube connector).

101mm (Dia.) male spigot.

R14 AutoCAD drawing available by e-mail.

#### Free Area

5980mm<sup>2</sup> (59.8cm<sup>2</sup>) (9¼"²) per unit.

#### Composition

Polypropylene.

#### Colours

Black.

#### Specification Paragraph

Manufacturer:

Rytons Building Products Ltd Tel: 01536 511874 Fax: 01536 310455

Email: admin@rytons.com Web: www.vents.co.uk (updated regularly)

Product ref: Rytons Horizontal Adaptor (ref HADAP100)

Accessories:

- Rytons Periscope® Underfloor Ventilator (ref PUFV to BBA 89/2321)

- Rytons '9x3' Non-Telescopic AirLiner® (ref TCL8LNR to BBA 89/2321)

#### Alternative Applications

Compatible with flexible hosing and can be connected to piping to ventilate a kitchen, habitable room, tumble dryer or dishwasher. A direct attachment to mechanical extractor fans.

## Technical Data Sheet

### Rytons Horizontal Adaptor

#### Photo Library

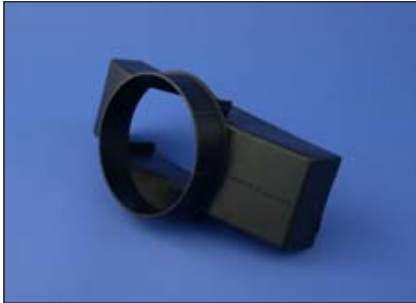

HADAP100 in conjunction with Rytons '9x3' Non-Telescopic AirLiner®



HADAP100 with 100mm (4") RytHose attached



HADAP100 in conjunction with Rytons Periscope® Underfloor Ventilator



#### UK Regulations, Standards and Guidelines

For underfloor ventilation refer to:

**The Building Regulations 2000, Approved Document C 2004 edition 4.14 b)** Any pipes needed to carry ventilating air should have a diameter of at least 100mm.

#### Handling Information

Box quantity: 12 number.

Box size: 35cm (W) x 26cm (H) x 23cm (D).

Box weight: 0.9kg.



Please recycle printouts where facilities exist.