

Technical Data Sheet

Rytons 125mm High Rise AirCore® with Hit & Miss Ventilator (Light and Draught Reducing)

www.vents.co.uk (search code: ACH75HM)

April 2010

Dimensional Drawing

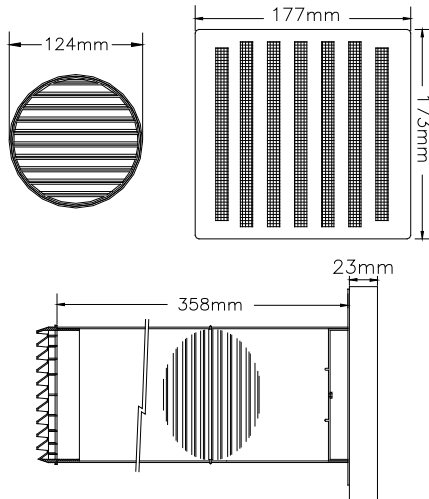

© Rytons

In-Situ Line Drawing

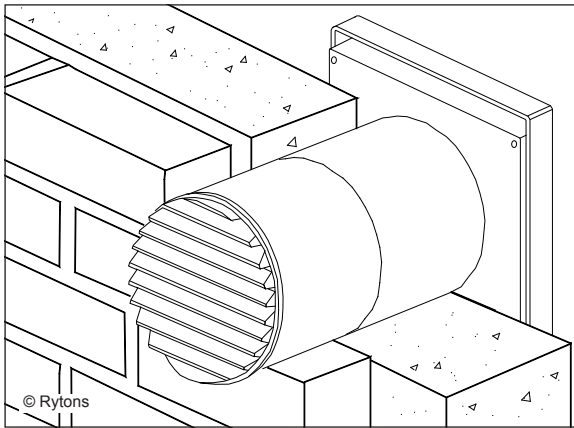

© Rytons

In-Situ Drawing

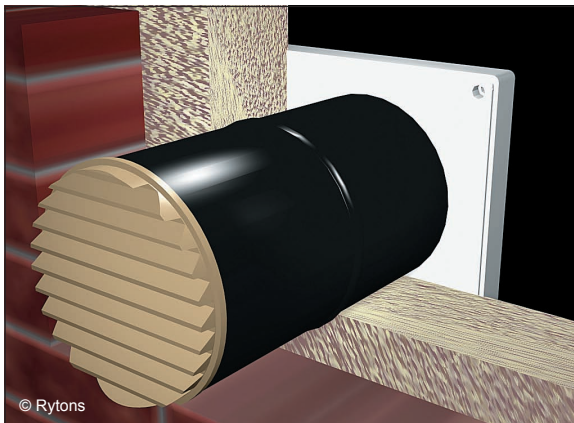

© Rytons

Approvals and Testing



Main Uses, Features and Benefits

- Background ventilator for a habitable room.
- Fitted from the inside for high level installations.
- May also suit rendered finishes as no external fixing required.
- Equivalent area calculated by the BRE at 1 Pa to BS EN 13141-1:2004.
- Internal baffles reduce light and draughts.
- Manually controlled internal hit & miss ventilator with flyscreen.
- Fits into core drilled hole - suitable for retrofit installations.
- Grilles U.V. stabilised to protect against deterioration by sunlight.



F30 Accessories/Sundry Items for Brick/Block/Stone Walling

059Plus

Specification clauses 17, 171

U90 General Ventilation - Domestic

Specification clauses 34, 340

Product Specification Code	Equivalent Area
Rytons ACH75HM	4371mm ² (43.71cm ²)

Size

Tube: 127mm (5") (Dia.) x 358mm (L).

(If necessary a maximum of 63mm may be cut from each end of the tube).

Internal Hit & Miss: 177mm (L) x 173mm (H).

AutoCAD drawing available by email.

Composition

External Louvre: U.V. stabilised high impact polystyrene.

Tube: High impact polystyrene. *Contains recycled plastic.*

Internal Hit & Miss: U.V. stabilised high impact polystyrene.

Colours

External Louvre: White, buff/sand, terracotta.

Tube: Black.

Internal Hit & Miss: White.



Technical Data Sheet

Rytons 125mm High Rise AirCore® with Hit & Miss Ventilator (Light and Draught Reducing)

www.vents.co.uk (search code: ACH75HM)

April 2010

Colour Key



Photo Library



Specification Paragraph

Manufacturer: Rytons Building Products Ltd
T: 01536 511874, F: 01536 310455, E: admin@rytons.com
Visit our website at www.vents.co.uk
Product ref:

- Rytons 125mm High Rise AirCore® with Hit & Miss Ventilator White (ref ACH75HMWH)
- Rytons 125mm High Rise AirCore® with Hit & Miss Ventilator Buff/Sand (ref ACH75HMBS)
- Rytons 125mm High Rise AirCore® with Hit & Miss Ventilator Terracotta (ref ACH75HMTC)

Type: High Rise Core Ventilator with Internal and External Grilles
Equivalent Area: 4371mm² (BRE tested)

Installation

Drill a hole using a 127mm core drill. Cut tube to length if necessary. Push fit round louvre into tube and insert into hole. Screw fix internal hit & miss ensuring the vent is fitted so that it can be opened and closed with a 'side to side' movement. To avoid discomfort from cold draughts the ventilator should be sited not less than 1.7m above floor level.

Extra Features and Benefits

Individually boxed sets for easy identification, handling and efficient installation.

Interlocking components aid correct positioning, alignment and easy installation.

Injection moulded one piece tube makes handling easier and installation quicker.

External water baffle prevents transfer of water across the cavity.

UK Regulations, Standards and Guidelines

The Building Regulations 2000, Approved Document F 2006 edition.
The Building (Scotland) Regulations 2007, Mandatory Standard 3.14.
The Building Regulations (Northern Ireland) 2000, Technical Booklet K.
British Standard BS 5250:2002.

A bit about the BRE

The Building Research Establishment Ltd is a respected independent testing authority. Since 2006 Rytons has commissioned the BRE to calculate the equivalent free area of their heat producing appliance and background ventilators giving installers, suppliers and homeowners the confidence that the air space is **accurate** and **verifiable**.

Handling Information

Box quantity: 1 set.
Box size: 44cm (W) x 19cm (H) x 22.5cm (D).
Box weight: 0.65kg.

Questions

Is an extension tube available?

Yes, refer to Rytons Background Ventilation Product Guide.

Is an acoustic option available?

Yes, refer to technical data sheet AAH5HM.



Please recycle printouts where facilities exist.

