

## Technical Data Sheet

### Rytons Cowled 150mm Baffled AirCore® (Light and Draught Reducing)

[www.vents.co.uk](http://www.vents.co.uk) (search code: AC9CWL)

May 2010

#### Dimensional Drawing

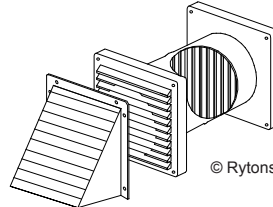
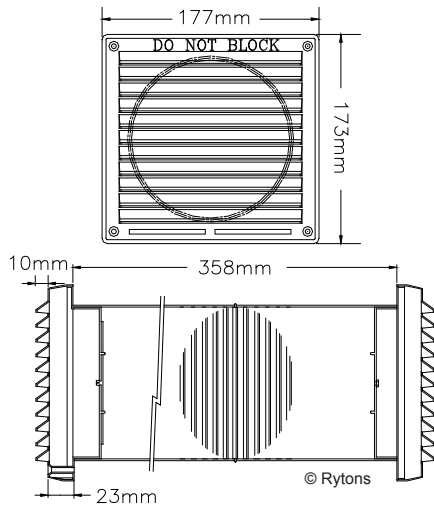

#### Approvals and Testing



#### Main Uses, Features and Benefits

- Combustion air vent for heat producing appliances.
- Room or compartment ventilator.
- Equivalent area calculated by the BRE at 15 Pa to BS 5440-2:2000.
- HETAS approved for use with solid fuel appliances.
- Cowl and internal baffles reduce light and draughts.
- Fits into core drilled hole - suitable for retrofit installations.
- Grilles U.V. stabilised to protect against deterioration by sunlight.



#### In-Situ Line Drawing

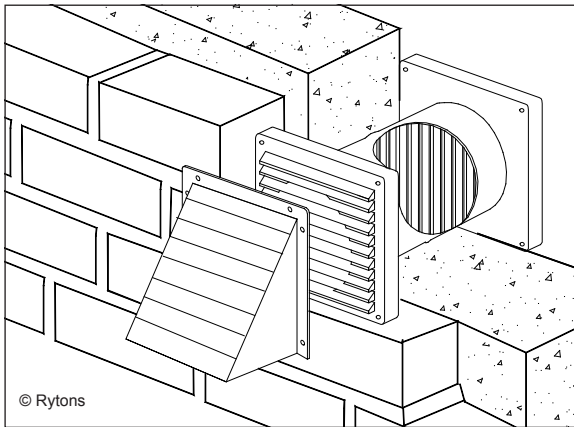

#### F30 Accessories/Sundry Items for Brick/Block/Stone Walling

n55Plus

Specification clauses 17, 171

U90 General Ventilation - Domestic

Specification clauses 30, 34, 310, 340

Product Specification Code	Equivalent Area
Rytons AC9CWL	8455mm <sup>2</sup> (84.55cm <sup>2</sup> ) (13"²)

#### Size

Cowl: 217mm (L) x 210mm (H) x 93mm (D).

Louvre Ventilators: 177mm (L) x 173mm (H).

Tube: 151mm (6") (Dia.) x 358mm (L).

(If necessary a maximum of 63mm may be cut from each end of the tube).

#### Gas Appliances

Suitable for an open-flued gas appliance installed in a room or internal space with a gross rated input up to 23kW (78476 Btu/h).

#### Solid Fuel Appliances

(e.g. Stoves, Range Cookers or Independent Boilers)

Closed appliance without a draught stabiliser fitted - suitable up to 20kW.

Closed appliance with a draught stabiliser fitted - suitable up to 13kW.

#### Composition

Cowl: U.V. stabilised high impact polystyrene.

External Louvre: U.V. stabilised high impact polystyrene.

Tube: High impact polystyrene. *Contains recycled plastic.*

Internal Louvre: U.V. stabilised high impact polystyrene.

#### Softening/Melting Points

Tube: Softening point 70°C. Melting point 120°C.

#### In-Situ Drawing

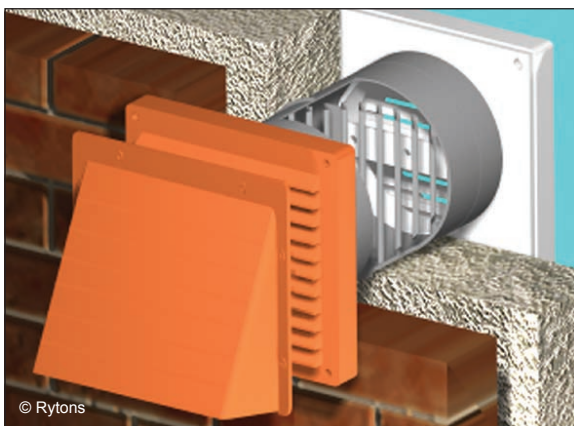

## Technical Data Sheet

[www.vents.co.uk](http://www.vents.co.uk) (search code: AC9CWL)

### Rytons Cowled 150mm Baffled AirCore® (Light and Draught Reducing)

May 2010

#### Colour Key



#### Photo Library

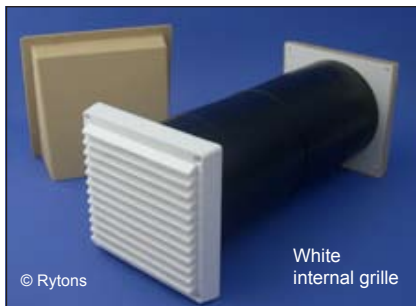
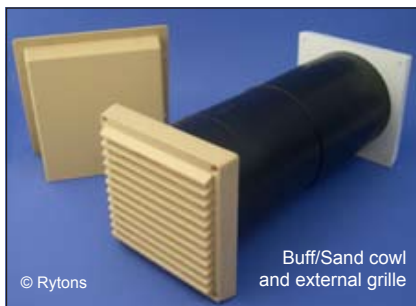

#### Colours

Cowl: White, buff/sand, terracotta.

External Louvre: White, buff/sand, terracotta.

Tube: Black.

Internal Louvre: White.

#### Specification Paragraph

Manufacturer: Rytons Building Products Ltd

T: 01536 511874, F: 01536 310455, E: admin@rytons.com

Visit our website at [www.vents.co.uk](http://www.vents.co.uk)

Product ref:

- Rytons Cowled 150mm Baffled AirCore® White (ref AC9WCWL)

- Rytons Cowled 150mm Baffled AirCore® Buff/Sand (ref AC9BCWL)

- Rytons Cowled 150mm Baffled AirCore® Terracotta (ref AC9TCWL)

Type: Core Ventilator with Cowl and Internal and External Grilles

Equivalent Area: 8455mm<sup>2</sup> (BRE tested)

#### Installation

Drill a hole using a 150mm core drill. Cut tube to length if necessary (maximum reduction 63mm from each end). Insert tube into hole. Push fit internal and external louvres (screw into position for extra security). Fasten cowl to the brickwork through the pre-formed holes in the flange around the cowl.

#### HETAS Approval

HETAS is the official body recognised by the government to approve solid fuel domestic heating appliances, fuels and services. Rytons is the only ventilation manufacturer to have solid fuel appliance ventilators approved by HETAS and is the only ventilation manufacturer recommended by HETAS to their registered engineers.

#### A bit about the BRE

The Building Research Establishment Ltd is a respected independent testing authority. Since 2006 Rytons has commissioned the BRE to calculate the equivalent free area of their heat producing appliance and background ventilators giving installers, suppliers and homeowners the confidence that the air space is **accurate** and **verifiable**.

#### Extra Features and Benefits

Individually boxed sets for easy identification, handling and efficient installation.

Interlocking components aid correct positioning, alignment and easy installation.

Injection moulded one piece tube makes handling easier and installation quicker.

External water baffle prevents transfer of water across the cavity.

Internal and external louvre grilles embossed with **DO NOT BLOCK**.

## Technical Data Sheet

[www.vents.co.uk](http://www.vents.co.uk) (search code: AC9CWL)

### Rytons Cowled 150mm Baffled AirCore® (Light and Draught Reducing)

May 2010

#### Top Tip

It may be possible to save installation time by securing the external grille to the backplate with a mastic sealant.



© Rytons

#### UK Regulations, Standards and Guidelines

##### For heat producing appliances (including solid fuel) refer to:

The Building Regulations 2000, Approved Document J.  
The Building (Scotland) Regulations 2005, Mandatory Standard 3.21.  
The Building Regulations (Northern Ireland) 2000, Technical Booklet L.  
British Standard BS 5440-2:2009.

##### For decorative fuel effect gas fires refer to:

British Standard BS 5871-3:2005.

#### Handling Information

Box quantity: 1 set.  
Box size: 44cm (W) x 19cm (H) x 22.5cm (D).  
Box weight: 0.929kg.

#### Questions

##### Is an acoustic option available?

Yes, refer to technical data sheets AAC625CW and AAC635CW.



Please recycle printouts where facilities exist.

