

Technical Data Sheet

Rytons 150mm AirCore®

www.vents.co.uk (search code: AC11)

May 2010

Dimensional Drawing

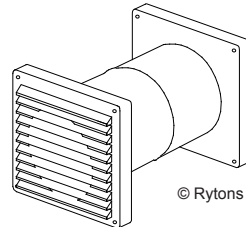
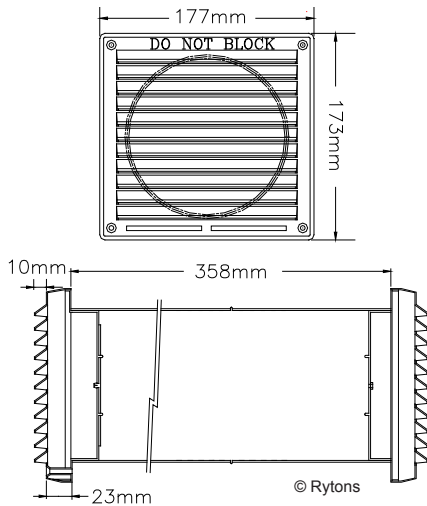

Approvals and Testing



Main Uses, Features and Benefits

- Combustion air vent for heat producing appliances.
- Room or compartment ventilator.
- Provides 115cm² equivalent area.
- Equivalent area calculated by the BRE at 15 Pa to BS 5440-2:2000.
- HETAS approved for use with solid fuel appliances.
- Fits into core drilled hole - suitable for retrofit installations.
- Grilles U.V. stabilised to protect against deterioration by sunlight.



In-Situ Line Drawing

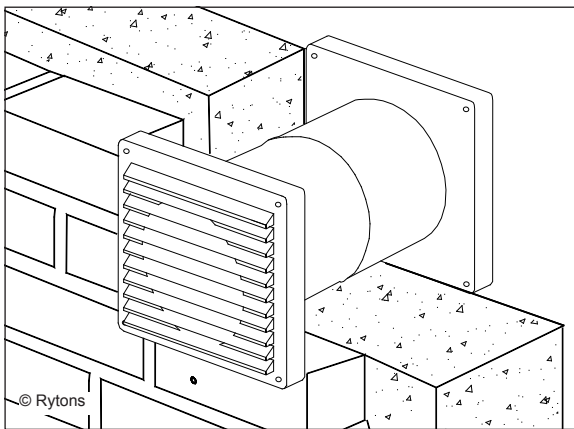

In-Situ Drawing

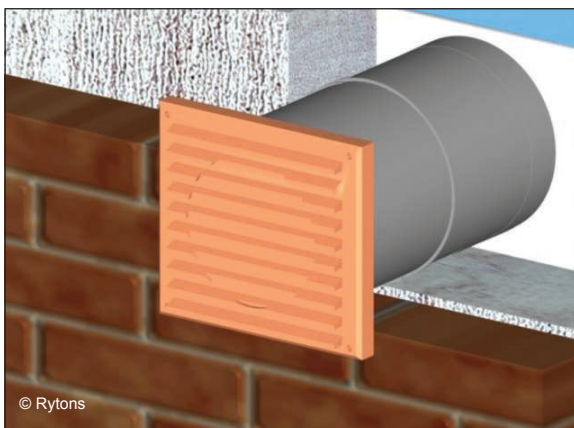

F30 Accessories/Sundry Items for Brick/Block/Stone Walling

Specification clauses 17, 171

U90 General Ventilation - Domestic

Specification clauses 30, 34, 310, 340

Product Specification Code	Equivalent Area
Rytons AC11	11500mm ² (115cm ²) (17¼"²)

Size

Louvre Ventilators: 177mm (L) x 173mm (H).

Tube: 151mm (6") (Dia.) x 358mm (L).

AutoCAD drawing available by email.

Gas Appliances

Suitable for an open-flued gas appliance installed in a room or internal space with a gross rated input up to 30kW (102360 Btu/h).

Solid Fuel Appliances

(e.g. Stoves, Range Cookers or Independent Boilers)

Closed appliance without a draught stabiliser fitted - suitable up to 25kW.

Closed appliance with a draught stabiliser fitted - suitable up to 16kW.

Composition

External Louvre: U.V. stabilised high impact polystyrene.

Tube: High impact polystyrene. *Contains recycled plastic.*

Internal Louvre: U.V. stabilised high impact polystyrene.

Softening/Melting Points

Tube: Softening point 70°C. Melting point 120°C.

Colours

External Louvre: White, buff/sand, terracotta.

Tube: Black.

Internal Louvre: White.



Technical Data Sheet

Rytons 150mm AirCore®

www.vents.co.uk (search code: AC11)

May 2010

Colour Key



Photo Library



Top Tip

It may be possible to save installation time by securing the external grille to the backplate with a mastic sealant.



Questions

Is a cowed option available for exposed areas?

Yes, refer to technical data sheet AC11CWL.

Is an acoustic option available?

Yes, refer to technical data sheets AAC625 and AAC635.

Specification Paragraph

Manufacturer: Rytons Building Products Ltd

T: 01536 511874, F: 01536 310455, E: admin@rytons.com

Visit our website at www.vents.co.uk

Product ref:

- Rytons 150mm AirCore® White (ref AC11WH)

- Rytons 150mm AirCore® Buff/Sand (ref AC11BS)

- Rytons 150mm AirCore® Terracotta (ref AC11TC)

Type: Core Ventilator with Internal and External Grilles

Equivalent Area: 11500mm² (BRE tested)

Installation

Drill a hole using a 150mm core drill. Cut tube to length if necessary. Insert tube into hole. Push fit internal and external louvres (screw into position for extra security). Consideration should be given to using Rytons AirCore® Cowl (ABC8) in exposed areas.

HETAS Approval

HETAS is the official body recognised by the government to approve solid fuel domestic heating appliances, fuels and services. Rytons is the only ventilation manufacturer to have solid fuel appliance ventilators approved by HETAS and is the only ventilation manufacturer recommended by HETAS to their registered engineers.

A bit about the BRE

The Building Research Establishment Ltd is a respected independent testing authority. Since 2006 Rytons has commissioned the BRE to calculate the equivalent free area of their heat producing appliance and background ventilators giving installers, suppliers and homeowners the confidence that the air space is **accurate** and **verifiable**.

Extra Features and Benefits

Individually boxed sets for easy identification, handling and efficient installation.

Interlocking components aid correct positioning, alignment and easy installation.

Injection moulded one piece tube makes handling easier and installation quicker.

External water baffle prevents transfer of water across the cavity.

Internal and external louvre grilles embossed with DO NOT BLOCK.

UK Regulations, Standards and Guidelines

For heat producing appliances (including solid fuel) refer to:

The Building Regulations 2000, Approved Document J.

The Building (Scotland) Regulations 2005, Mandatory Standard 3.21.

The Building Regulations (Northern Ireland) 2000, Technical Booklet L.

British Standard BS 5440-2:2009.

For decorative fuel effect gas fires refer to:

British Standard BS 5871-3:2005.

Handling Information

Box quantity: 1 set.

Box size: 44cm (W) x 19cm (H) x 22.5cm (D).

Box weight: 0.74kg.



Please recycle printouts where facilities exist.

