

## Technical Data Sheet

### Rytons Cowled 125mm AirCore® (Light and Draught Reducing)

[www.vents.co.uk](http://www.vents.co.uk) (search code: AC10CWL)

May 2010

#### Dimensional Drawing

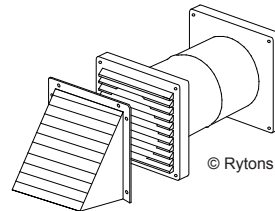
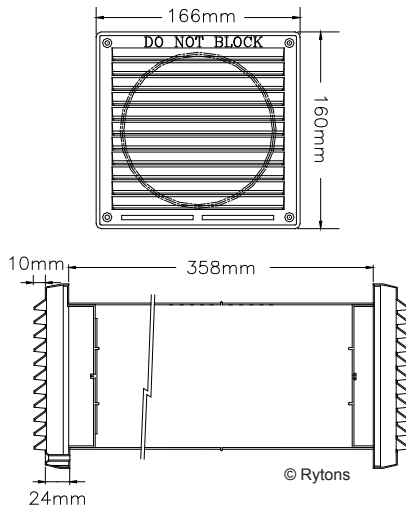

#### Approvals and Testing



#### Main Uses, Features and Benefits

- Combustion air vent for heat producing appliances.
- Room or compartment ventilator.
- Equivalent area calculated by Advantica at 15 Pa to BS 5440-2:2000.
- HETAS approved for use with solid fuel appliances.
- Cowl reduces light and draughts.
- Fits into core drilled hole - suitable for retrofit installations.
- Grilles U.V. stabilised to protect against deterioration by sunlight.



#### In-Situ Line Drawing

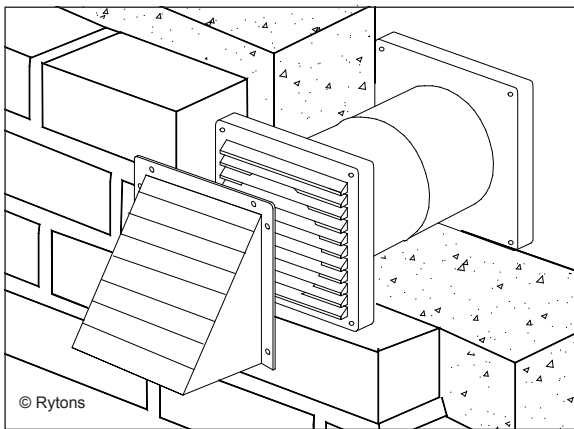

#### F30 Accessories/Sundry Items for Brick/Block/Stone Walling



Specification clauses 17, 171

**U90 General Ventilation - Domestic**

Specification clauses 30, 34, 310, 340

Product Specification Code	Equivalent Area
Rytons AC10CWL	9300mm <sup>2</sup> (93cm <sup>2</sup> ) (14¼"²)

#### Size

Cowl: 217mm (L) x 210mm (H) x 93mm (D).

Louvre Ventilators: 166mm (L) x 160mm (H).

Tube: 127mm (5") (Dia.) x 358mm (L).

#### Gas Appliances

Suitable for an open-flued gas appliance installed in a room or internal space with a gross rated input up to 25kW (85300 Btu/h).

#### Solid Fuel Appliances

(e.g. Stoves, Range Cookers or Independent Boilers)

Closed appliance without a draught stabiliser fitted - suitable up to 21kW.

Closed appliance with a draught stabiliser fitted - suitable up to 14kW.

#### Composition

Cowl: U.V. stabilised high impact polystyrene.

External Louvre: U.V. stabilised high impact polystyrene.

Tube: High impact polystyrene. *Contains recycled plastic.*

Internal Louvre: U.V. stabilised high impact polystyrene.

#### Softening/Melting Points

Tube: Softening point 70°C. Melting point 120°C.

#### In-Situ Drawing



## Technical Data Sheet

### Rytons Cowled 125mm AirCore® (Light and Draught Reducing)

[www.vents.co.uk](http://www.vents.co.uk) (search code: AC10CWL)

May 2010

#### Colour Key



#### Photo Library

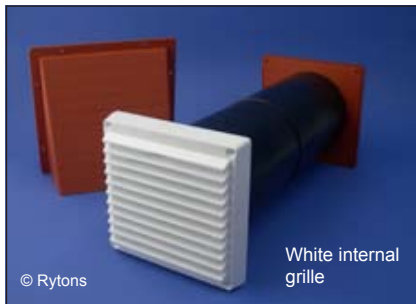
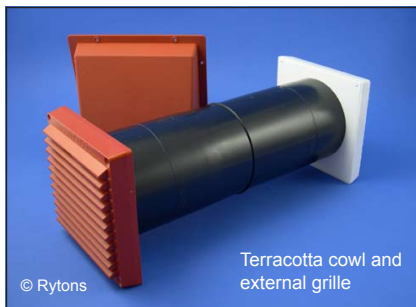

Gold and chrome effect louvres are a stylish alternative to a standard white internal grille

#### Colours

Cowl: White, buff/sand, terracotta.

External Louvre: White, buff/sand, terracotta.

Tube: Black.

Internal Louvre: White.

Gold effect louvre available separately - code LV110GLD.

Chrome effect louvre available separately - code LV110CHR.

#### Specification Paragraph

Manufacturer: Rytons Building Products Ltd

T: 01536 511874, F: 01536 310455, E: admin@rytons.com

Visit our website at [www.vents.co.uk](http://www.vents.co.uk)

Product ref:

- Rytons Cowled 125mm AirCore® White (ref AC10WCWL to BBA 94/3071)

- Rytons Cowled 125mm AirCore® Buff/Sand (ref AC10BCWL to BBA 94/3071)

- Rytons Cowled 125mm AirCore® Terracotta (ref AC10TCWL to BBA 94/3071)

Type: Core Ventilator with Cowl and Internal and External Grilles

Equivalent Area: 9300mm<sup>2</sup> (Advantica tested)

#### Installation

Drill a hole using a 127mm core drill. Cut tube to length if necessary. Insert tube into hole. Push fit internal and external louvres (screw into position for extra security). Fasten cowl to the brickwork through the pre-formed holes in the flange around the cowl.

#### BBA Approval

Rytons has 73 British Board of Agrément approved products; the largest range on the market. BBA certification is third party evaluation and accreditation, and approved products are accepted by building control officers, architects, engineers and surveyors nationwide. The NHBC also accept products approved by the BBA when used as stated in the relevant BBA certificate. Rytons also has an Irish Building Regulation Statement for each of their three BBA certificates.

#### HETAS Approval

HETAS is the official body recognised by the government to approve solid fuel domestic heating appliances, fuels and services. Rytons is the only ventilation manufacturer to have solid fuel appliance ventilators approved by HETAS and is the only ventilation manufacturer recommended by HETAS to their registered engineers.

#### A bit about Advantica

Advantica Technologies, previously known as British Gas Technologies and now GL Industrial Services, developed the dynamic test procedure for calculating the equivalent area of a ventilator. Advantica testing gives installers, suppliers and homeowners the assurance that the air space is **accurate** and **verifiable**.

## Technical Data Sheet

### Rytons Cowled 125mm AirCore® (Light and Draught Reducing)

[www.vents.co.uk](http://www.vents.co.uk) (search code: AC10CWL)

May 2010

#### Top Tip

It may be possible to save installation time by securing the external grille to the backplate with a mastic sealant.



#### Extra Features and Benefits

Individually boxed sets for easy identification, handling and efficient installation.

Interlocking components aid correct positioning, alignment and easy installation.

Injection moulded one piece tube makes handling easier and installation quicker.

External water baffle prevents transfer of water across the cavity.

Internal and external louvre grilles embossed with DO NOT BLOCK.

#### UK Regulations, Standards and Guidelines

**For heat producing appliances (including solid fuel) refer to:**

The Building Regulations 2000, Approved Document J.

The Building (Scotland) Regulations 2005, Mandatory Standard 3.21.

The Building Regulations (Northern Ireland) 2000, Technical Booklet L.

British Standard BS 5440-2:2009.

**For decorative fuel effect gas fires refer to:**

British Standard BS 5871-3:2005.

#### Handling Information

Box quantity: 1 set.

Box size: 44cm (W) x 19cm (H) x 22.5cm (D).

Box weight: 0.74kg.

#### Questions

##### Is an extension tube available?

Yes, tubes are available separately ref: AC10TUBE.

##### Is an acoustic option available?

Yes, refer to technical data sheet AAC5CWL.



Please recycle printouts where facilities exist.

