

## Technical Data Sheet

### Rytons 150mm Acoustic AirCore® (41 dB) (Sound Reducing)

[www.vents.co.uk](http://www.vents.co.uk) (search code: AAC635)

May 2010

#### Dimensional Drawing

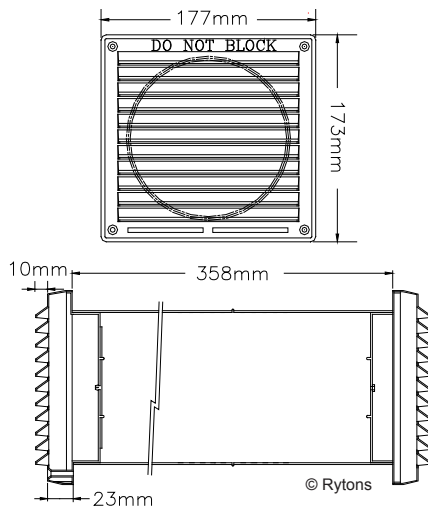

#### In-Situ Line Drawing

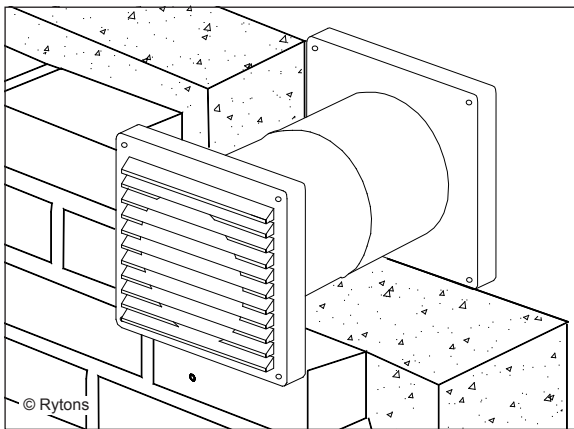

#### In-Situ Drawing

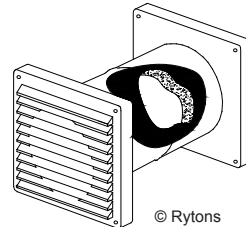
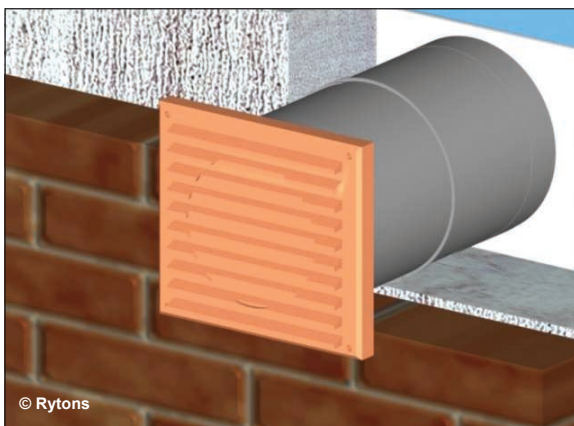

#### Approvals and Testing



#### Main Uses, Features and Benefits

- Combustion air vent for heat producing appliances.
- Room or compartment ventilator.
- Acoustic lining reduces sound to 41 dB  $D_{n,e,w}$
- $D_{n,e,w}$  figure calculated by the BRE in accordance with BS EN ISO 717-1:1997.
- HETAS approved for use with solid fuel appliances.
- Equivalent area calculated by the BRE at 15 Pa to BS 5440-2:2000.
- Fits into core drilled hole - suitable for retrofit installations.
- Grilles U.V. stabilised to protect against deterioration by sunlight.



#### F30 Accessories/Sundry Items for Brick/Block/Stone Walling

059Plus

Specification clauses 17, 171

**U90 General Ventilation - Domestic**

Specification clauses 30, 34, 310, 340

Product Specification Code	$D_{n,e,w}$	Equivalent Area
Rytons AAC635	41 dB	5412mm <sup>2</sup> (54.12cm <sup>2</sup> ) (8¼"²)

#### Size

Louvre Ventilators: 177mm (L) x 173mm (H).

Tube: 151mm (6") (Dia.) x 358mm (L).

AutoCAD drawing available by email.

#### Gas Appliances

Suitable for an open-flued gas appliance installed in a room or internal space with a gross rated input up to 17kW.

#### Solid Fuel Appliances

(e.g. Stoves, Range Cookers or Independent Boilers)

Closed appliance without a draught stabiliser fitted - suitable up to 14kW.

Closed appliance with a draught stabiliser fitted - suitable up to 9kW.

#### Composition

External Louvre: U.V. stabilised high impact polystyrene.

Tube: High impact polystyrene containing sound absorbent foam lining.

Tube contains recycled plastic.

Internal Louvre: U.V. stabilised high impact polystyrene.

#### Softening/Melting Points

Tube (unlined): Softening point 70°C. Melting point 120°C.



## Technical Data Sheet

[www.vents.co.uk](http://www.vents.co.uk) (search code: AAC635)

# Rytons 150mm Acoustic AirCore® (41 dB) (Sound Reducing)

May 2010

### Colour Key



### Photo Library



### Colours

External Louvre: White, buff/sand, terracotta.

Tube: Black.

Internal Louvre: White.

### Specification Paragraph

Manufacturer: Rytons Building Products Ltd

T: 01536 511874, F: 01536 310455, E: admin@rytons.com

Visit our website at [www.vents.co.uk](http://www.vents.co.uk)

Product ref:

- Rytons 150mm Acoustic AirCore® (41 dB) White (ref AAC635WH)

- Rytons 150mm Acoustic AirCore® (41 dB) Buff/Sand (ref AAC635BS)

- Rytons 150mm Acoustic AirCore® (41 dB) Terracotta (ref AAC635TC)

Type: Acoustic Core Ventilator with Internal and External Grilles

Equivalent Area: 5412mm<sup>2</sup> (BRE tested)

### Installation

Drill a hole using a 151mm core drill. Cut tube to length if necessary. Insert tube into hole. Push fit internal and external louvres to finish (screw to the brickwork for extra security). Consideration should be given to using Rytons AirCore® Cowl (ABC8) in exposed areas.

### Extra Features and Benefits

Individually boxed sets for easy identification, handling and efficient installation.

Interlocking components aid correct positioning, alignment and easy installation.

Injection moulded one piece tube makes handling easier and installation quicker.

External water baffle prevents transfer of water across the cavity.

Internal and external louvre grilles embossed with DO NOT BLOCK.

### UK Regulations, Standards and Guidelines

Measurement of airborne sound insulation made by the BRE in accordance with BS EN 20140-10:1992 and BS EN ISO 140-3:1995. Single number quantities were calculated in accordance with BS EN ISO 717-1:1997 'Rating of sound insulation in buildings and of building elements'.

### For heat producing appliances (including solid fuel) refer to:

The Building Regulations 2000, Approved Document J.

The Building (Scotland) Regulations 2005, Mandatory Standard 3.21.

The Building Regulations (Northern Ireland) 2000, Technical Booklet L.

British Standard BS 5440-2:2009.

### For decorative fuel effect gas fires refer to:

British Standard BS 5871-3:2005.

### The Building Regulations 2000, Approved Document J

**1.16** In noisy areas, it may be necessary to install proprietary noise attenuated ventilators to limit the entry of noise into the building.

## Technical Data Sheet

[www.vents.co.uk](http://www.vents.co.uk) (search code: AAC635)

### Rytons 150mm Acoustic AirCore® (41 dB) (Sound Reducing)

May 2010

Rytons AAC635 Converted Octave Band Values	
63 Hz	33.8 dB
125 Hz	41.8 dB
250 Hz	35.1 dB
500 Hz	34.8 dB
1000 Hz	51.9 dB
2000 Hz	60.5 dB
4000 Hz	63.9 dB

All figures are reproduced in good faith and to the best of our knowledge are true and accurate. Customers should satisfy themselves that the product is suitable for the intended purpose by using this information in conjunction with the BRE acoustic test report available online at [www.vents.co.uk](http://www.vents.co.uk) and from Rytons sales office.

#### A bit about the BRE

The Building Research Establishment Ltd is a respected independent testing authority. BRE Acoustics holds UKAS accreditation for the measurement of sound insulation in the field and the laboratory. The measurements were conducted using the procedures accredited by UKAS. Since 2006 Rytons has commissioned the BRE to calculate the equivalent free area of their heat producing appliance and background ventilators giving installers, suppliers and homeowners the confidence that the air space is **accurate** and **verifiable**.

#### Handling Information

Box quantity: 1 set.  
Box size: 44cm (W) x 19cm (H) x 22.5cm (D).  
Box weight: 0.92kg.

#### Questions

##### Is a copy of the BRE test report available?

Yes, online at [www.vents.co.uk](http://www.vents.co.uk) or from Rytons sales office.

##### Is a cowl option available for exposed areas?

Yes, refer to technical data sheet AAC635CW.

##### Will installing more than one vent to achieve a greater free area have an effect on the acoustic performance?

Yes, by installing two vents anywhere in a room the combined performance of both vents would be reduced by 3dB. Installing four vents would give a reduction of 6dB.

##### Will the vent reduce sound from inside to outside as well as from outside to inside?

The BRE has advised us that it's reasonable to assume that 'reciprocity' applies to the vents. That is, the third octave values for sound reduction index are the same in both directions (out to in and in to out).



Please recycle printouts where facilities exist.

