

## Technical Data Sheet

### Rytons Cowled 125mm Acoustic AirCore® (40 dB) (Sound, Light and Draught Reducing)

[www.vents.co.uk](http://www.vents.co.uk) (search code: AAC5CWL)

May 2010

#### Dimensional Drawing

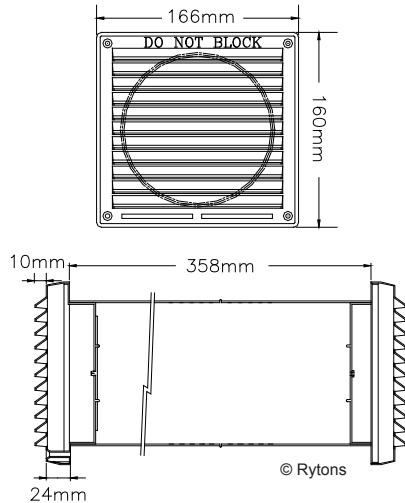

#### In-Situ Line Drawing

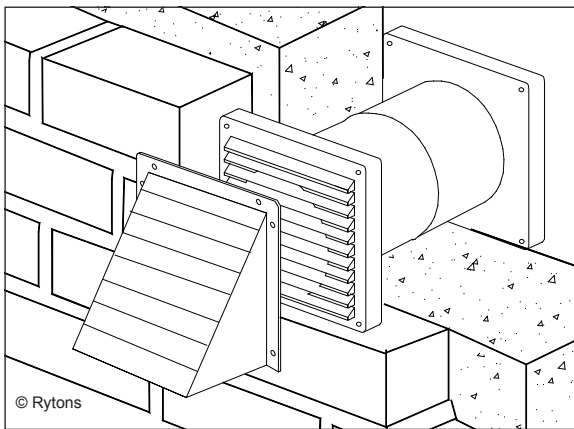

#### In-Situ Drawing



#### Approvals and Testing

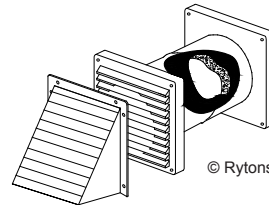

#### Main Uses, Features and Benefits

- Combustion air vent for heat producing appliances.
- Room or compartment ventilator.
- Acoustic lining reduces sound to 40 dB  $D_{n,e,w}$
- $D_{n,e,w}$  figure calculated by the BRE in accordance with BS EN ISO 717-1:1997.
- HETAS approved for use with solid fuel appliances.
- Equivalent area calculated by Advantica at 15 Pa to BS 5440-2:2000.
- Cowl reduces light and draughts.
- Fits into core drilled hole - suitable for retrofit installations.
- Grilles and cowl U.V. stabilised to protect against deterioration by sunlight.



#### F30 Accessories/Sundry Items for Brick/Block/Stone Walling

Specification clauses 17, 171

#### U90 General Ventilation - Domestic

Specification clauses 30, 34, 310, 340

Product Specification Code	$D_{n,e,w}$	Equivalent Area
Rytons AAC5CWL	40 dB	3940mm <sup>2</sup> (39.4cm <sup>2</sup> ) (6"²)

#### Size

Cowl: 217mm (L) x 210mm (H) x 93mm (D).

Louvre Ventilators: 166mm (L) x 160mm (H).

Tube: 127mm (5") (Dia.) x 358mm (L).

AutoCAD drawings available by email.

#### Gas Appliances

Suitable for an open-flued gas appliance installed in a room or internal space with a gross rated input up to 14kW.

#### Solid Fuel Appliances

(e.g. Stoves, Range Cookers or Independent Boilers)

Closed appliance without a draught stabiliser fitted - suitable up to 12kW.

Closed appliance with a draught stabiliser fitted - suitable up to 7kW.

#### Composition

Cowl: U.V. stabilised high impact polystyrene.

External Louvre: U.V. stabilised high impact polystyrene.

Tube: High impact polystyrene containing sound absorbent foam lining.

Tube contains recycled plastic.

Internal Louvre: U.V. stabilised high impact polystyrene.

#### Softening/Melting Points

Tube (unlined): Softening point 70°C. Melting point 120°C.



## Technical Data Sheet

[www.vents.co.uk](http://www.vents.co.uk) (search code: AAC5CWL)

# Rytons Cowled 125mm Acoustic AirCore® (40 dB) (Sound, Light and Draught Reducing)

May 2010

### Colour Key



### Photo Library

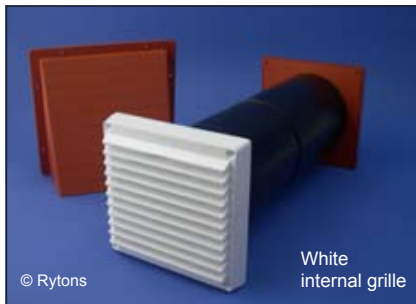
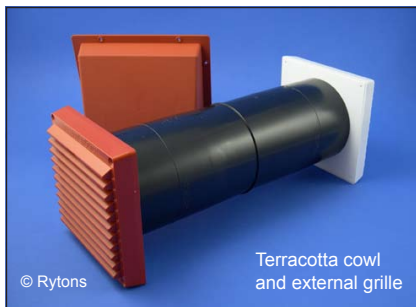

Gold and chrome effect louvres are a stylish alternative to a standard white internal grille

### Colours

Cowl: White, buff/sand, terracotta.

External Louvre: White, buff/sand, terracotta.

Tube: Black.

Internal Louvre: White.

Gold effect louvre available separately - code LV110GLD.

Chrome effect louvre available separately - code LV110CHR.

### Specification Paragraph

Manufacturer: Rytons Building Products Ltd

T: 01536 511874, F: 01536 310455, E: admin@rytons.com

Visit our website at [www.vents.co.uk](http://www.vents.co.uk)

Product ref:

- Rytons Cowled 125mm Acoustic AirCore® (40 dB) White (ref AAC5WCWL to BBA 94/3071)

- Rytons Cowled 125mm Acoustic AirCore® (40 dB) Buff/Sand (ref AAC5BCWL to BBA 94/3071)

- Rytons Cowled 125mm Acoustic AirCore® (40 dB) Terracotta (ref AAC5TCWL to BBA 94/3071)

Type: Acoustic Core Ventilator with Cowl and Internal and External Grilles

Equivalent Area: 3940mm<sup>2</sup> (Advantica tested)

### Installation

Drill a hole using a 127mm core drill. Cut tube to length if necessary. Insert tube into hole. Push fit internal and external louvres (screw to the brickwork for extra security). Fasten cowl to the brickwork through the pre-formed holes in the flange around the cowl.

### BBA Approval

Rytons has 73 British Board of Agrément approved products; the largest range on the market. BBA certification is third party evaluation and accreditation, and approved products are accepted by building control officers, architects, engineers and surveyors nationwide. The NHBC also accept products approved by the BBA when used as stated in the relevant BBA certificate. Rytons also has an Irish Building Regulation Statement for each of their three BBA certificates.

### HETAS Approval

HETAS is the official body recognised by the government to approve solid fuel domestic heating appliances, fuels and services. Rytons is the only ventilation manufacturer to have solid fuel appliance ventilators approved by HETAS and is the only ventilation manufacturer recommended by HETAS to their registered engineers.

### A bit about the BRE

The Building Research Establishment Ltd is a respected independent testing authority. BRE Acoustics holds UKAS accreditation for the measurement of sound insulation in the field and the laboratory. The measurements were conducted using the procedures accredited by UKAS.

### A bit about Advantica

Advantica Technologies, previously known as British Gas Technologies and now GL Industrial Services, developed the dynamic test procedure for calculating the equivalent area of a ventilator. Advantica testing gives installers, suppliers and homeowners the assurance that the air space is **accurate** and **verifiable**.

## Technical Data Sheet

[www.vents.co.uk](http://www.vents.co.uk) (search code: AAC5CWL)

### Ryttons Cowled 125mm Acoustic AirCore® (40 dB) (Sound, Light and Draught Reducing)

May 2010

Ryttons AAC5CWL Converted Octave Band Values	
63 Hz	34.5 dB
125 Hz	41.8 dB
250 Hz	32.9 dB
500 Hz	33.6 dB
1000 Hz	51.6 dB
2000 Hz	63.8 dB
4000 Hz	68.1 dB

All figures are reproduced in good faith and to the best of our knowledge are true and accurate. Customers should satisfy themselves that the product is suitable for the intended purpose by using this information in conjunction with the BRE acoustic test report available online at [www.vents.co.uk](http://www.vents.co.uk) and from Ryttons sales office.

#### Extra Features and Benefits

Individually boxed sets for easy identification, handling and efficient installation.

Interlocking components aid correct positioning, alignment and easy installation.

Injection moulded one piece tube makes handling easier and installation quicker.

External water baffle prevents transfer of water across the cavity.

Internal and external louvre grilles embossed with DO NOT BLOCK.

#### UK Regulations, Standards and Guidelines

Measurement of airborne sound insulation made by the BRE in accordance with BS EN 20140-10:1992 and BS EN ISO 140-3:1995. Single number quantities were calculated in accordance with BS EN ISO 717-1:1997 'Rating of sound insulation in buildings and of building elements'.

#### For heat producing appliances (including solid fuel) refer to:

The Building Regulations 2000, Approved Document J.

The Building (Scotland) Regulations 2005, Mandatory Standard 3.21.

The Building Regulations (Northern Ireland) 2000, Technical Booklet L.

British Standard BS 5440-2:2009.

#### For decorative fuel effect gas fires refer to:

British Standard BS 5871-3:2005.

#### The Building Regulations 2000, Approved Document J

1.16 In noisy areas, it may be necessary to install proprietary noise attenuated ventilators to limit the entry of noise into the building.

#### Handling Information

Box quantity: 1 set.

Box size: 44cm (W) x 19cm (H) x 22.5cm (D).

Box weight: 0.84kg.

## Questions

#### Is a copy of the BRE test report available?

Yes, online at [www.vents.co.uk](http://www.vents.co.uk) or from Ryttons sales office.

#### Will installing more than one vent to achieve a greater free area have an effect on the acoustic performance?

Yes, by installing two vents anywhere in a room the combined performance of both vents would be reduced by 3dB. Installing four vents would give a reduction of 6dB.

#### Will the vent reduce sound from inside to outside as well as from outside to inside?

The BRE has advised us that it's reasonable to assume that 'reciprocity' applies to the vents. That is, the third octave values for sound reduction index are the same in both directions (out to in and in to out).



Please recycle printouts where facilities exist.

